



# HVNI<sup>®</sup>

**HIGH VOLTAGE, INC.**  
**AC DIELECTRIC TEST SETS**  
PAR SERIES PRODUCT CATALOG

# PAR SERIES CONTENTS

AC Dielectric Test Sets for High Capacitance Loads with Less Power ....	2
Why Resonant Technology? .....	3
Calculating Test Currents .....	3
Controls and Configurations .....	4
Models and Specifications .....	5
High Voltage Section Configurations .....	6
Optional Accessories .....	7

# HVI – AC DIELECTRIC TEST SETS FOR HIGH CAPACITANCE LOADS WITH LESS POWER

The PAR Series models are high voltage AC Dielectric Test Sets used for testing many types of utility substation apparatus, aerial lifts, cables, and other loads requiring power frequency AC voltage to perform Withstand/Proof testing and Diagnostic testing: Partial Discharge and Tan Delta/Power Factor. This model line provides a high power and high voltage AC output like conventional 50/60 Hz. test sets. However, the PAR Series is of unique design intended to test highly capacitive apparatus and cables. Its design tests these loads while minimizing the input power, size, weight, and cost of the supply. The PAR Series uses Resonant Technology, specifically: Variable Inductance Parallel Resonance.

## Features

- Full Featured PLC Controller
- Auto/Manual Output Mode selection
- Continuously adjustable motorized output voltage control
- Programmable output Rate of Rise: 500 – 5000 volts/second
- Fixed primary current overload, factory set to 120% of current
- Adjustable secondary current overload: 10-110% of rating
- “Zero Start” and External Interlock provision
- Secondary connected volt and current meters



## Typical Testing Applications



ISO Phase Bus & Switchgear Testing



Motor & Generator Coil Testing



Cable Testing

## Why Resonance Technology?

### High Voltage Testing With Less Power, Current and Costs

Resonance Technology is used to AC test highly capacitive electrical apparatus or power cable using 50/60 Hz. power frequency. The charging currents of these capacitive loads are typically very high, requiring AC hipots to be rated for hundreds of kVA in power. Resonant technology uses basic and long proven electrical principles for its design and operation to reduce the levels of power consumption needed, permitting high voltage AC testing to be performed more economically than otherwise possible.

If the capacitive nature of the load can be compensated for by inserting an equivalent inductance in series or parallel, then the input power and current required to the supply is greatly reduced. By “tuning” the inductance of the test set to match the capacitance of the load, a controlled Resonance is achieved, High voltage can be applied with far less current and power source than otherwise possible.

Using the PAR Series, the input current required of the supply is typically 10x – 30x less than if conventional fixed inductance power supplies were used. The HV transformer, or reactor, design includes a variably adjustable air gapped steel core to alter the Inductance of the system to compensate for the Capacitance of the load tested. The intention is to create a controlled resonance situation where  $L = C$ , leaving only the resistive elements of the load needing current/ power from the test set.

## Calculating Test Currents

$$\text{Amps} = 2\pi f C V \text{ or } A = \omega C V \quad \omega \text{ (omega)} = 2\pi f$$

$f$  = Test frequency in Hertz (Hz)

$C$  = Load capacitance in Farads (F)

$V$  = Test voltage in volts (V)

Resistance =  $R$ ,  $X_L = \omega L$ ,  $X_C = 1/\omega C$   
 $\omega = 2\pi f$  ( $f$  = frequency)  
 $\omega$  for 50 Hz. = 314  $\omega$  for 60 Hz. = 377

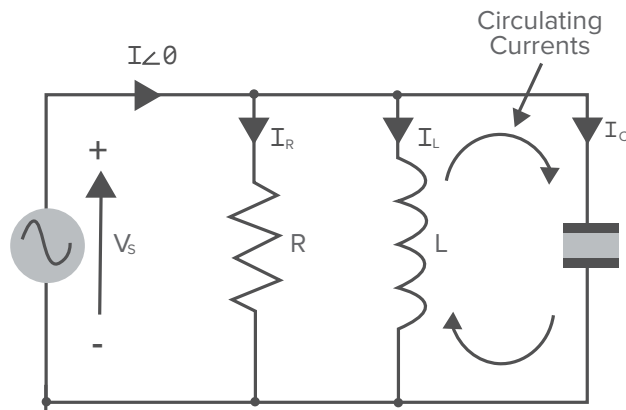

## Quality Factor "Q"

The Quality "Q" Factor is a measure of the level of power input reduction to the test set to deliver the power needed for a test. The Q, or quality, factor of a resonant circuit is a measure of the purity, or quality, of a resonant circuit. Q is the ratio of power stored (reactance) to power dissipated (resistance). In a parallel resonant circuit, the power, or kVA, across the load is approximately Q times the total system input power. For example:

1. A circuit with a Q of 20 would draw 1 kVA of input power from the mains for approximately 20 kVA of reactive power across the load.
2. A parallel resonant set, rated for 50 kVac @ 5 A output, tuned to the capacitive reactance of a bus duct or switchgear could deliver 250 kVA of apparent power to the load while drawing less than 10 kVA of power from the utility mains.
3. A generator stator winding, with a typical Q of 10, would draw less than 11 kVA from the mains while 100 kVA of reactive power is applied to the coils.

## Controls and Configuration

### C5 Controls - PLC programmed and controlled – any kVA

The C5 PLC controller provides an on-board PLC for complete operational and programming control and includes a PC interface to download tests results for report generation. The PLC can fully automate repetitive testing in automatic mode or perform simple hipot tests in manual mode. Test profiles for automatic mode can be preset at the factory or can be entered via the touch screen control. Operation is easily modified using Ladder Logic Programming. The C5 controller allows the user to fully program the operation of the set from the PLC and allows complete downloading of test results for report generation using your reporting software

- 320 x 240 color touch screen display for programming and operation
- Graphical display of output voltage and current during test
- Output voltage and current final test results displayed
- PC Interface for data download via RS-232
- Save and recall test profiles easily
- External interlock provisions

User Selectable/Settable Parameters:

- Automatic or Manual Mode
- Voltage set point
- Over Current set point
- Test Dwell Timer
- Voltage Rate of Rise (10-100 Seconds)

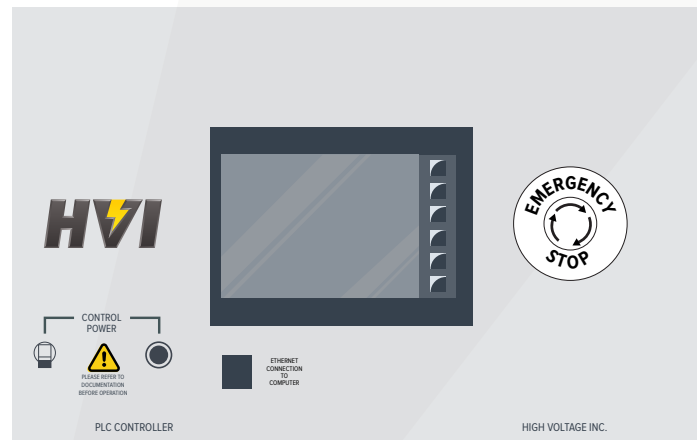

## Controls and Configuration

The model ratings offered by HVI are designed to be optimal for factory or field testing motors and generators as well as substation apparatus like switchgear, bus ducts, arrestors or bushings, and shorter MV cable lengths. Other sizes are available on a custom basis. (HVI produces only Parallel Resonant, no Series).

Model	OUTPUT				INPUT				
	Voltage		kVA	Amps	Voltage		kVA	Amps	Freq.
PAR-1680FC5	0 - 16 kVac	@	80 kVA	5 A	230 V	@	10 kVA	45 A	50/60 Hz.
PAR-32/16160FC5	0 - 16/32 kVac	@	160 kVA	5 A	230 V	@	20 kVA	90 A	50/60 Hz
PAR-32250FC5	0 - 32 kVac	@	250 kVA	8 A	230 V	@	20 kVA	90 A	50/60 Hz
PAR-50250FC5	0 - 50 kVac	@	250 kVA	5 A	230 V	@	20 kVA	90 A	50/60 Hz
PAR-100100FC5	0 - 100 kVac	@	100 kVA	1 A	230 V	@	20 kVA	90 A	50/60 Hz

**Size & Weight (approximate) - All models CE compliant**

### 10 kVA Input Models

Controller: 21"w x 25.5"d x 31"h, 210 lbs. 53w x 65d x 79h cm, 95 kg  
 HV Tank: 28"w x 28"d x 37"h, 800 lbs. 71w x 71d x 94h cm, 364 kg

### 20 kVA Input Models

Controller: 22"w x 25.5"d x 47.5"h, 310 lbs. 56w x 65d x 121h cm, 141 kg  
 HV Tank: 30"w x 30"d x 52"h, 1100 lbs. 76w x 76d x 132h cm, 499 kg

### Optional Upgrades



#### Flashing Warning Light

Flashing Red Warning Lamp that illuminates when the high voltage circuit has been energized. Available on all control packages.



#### Safety Light Stack

Status light option, illuminates green when the high voltage circuit is not energized and illuminates red when the high voltage circuit is energized. Available on all control packages.



#### Safety Key Interlock Switch

Front panel mounted key operated interlock switch. Available on all control packages.



#### Casters

2 inch or 6 inch casters mounted under the Control and/or High Voltage Section. Available on all control packages.

## High Voltage Section Configurations

The high voltage section of every PAR Parallel Resonant AC Test Set is housed inside of a reinforced steel tank terminated with a phenolic output bushing and shielded EPR cable with stress cones.

A half voltage, full kVA secondary output is optional on many of the PAR Parallel Resonant AC Test Sets. This allows for lower voltage but higher current testing when compared to the full voltage, full kVA output tap. Both output voltage taps will be active at the same time.



## Optional Accessories



### **DVR-150**

The DVR-150 is a precision voltage divider used to verify the voltage calibration of your PAR Parallel Resonant AC Dielectric Test Set.



### **Grounding Sticks**

Safely confirm the device under test has been discharge and is at at ground potential before handling after testing.



### **Hand and Foot Safety Interlock Switches**

Dead man style safety switches that connect to the external interlock provisions on the rear terminal block of the PAR Parallel Resonant AC Dielectric Test set The switch must be depressed before "HV On" and remain depressed during the duration of the testing. Releasing the switch has the same effect as hitting "HV Off", turning off the high voltage circuit. Supplied with 12 foot lead.







-  [hvinc.com](http://hvinc.com)
-  31 County Rt. 7A • Copake, NY 12516
-  phone: 518.329.3275
-  fax: 518.329.3271
-  email: [sales@hvinc.com](mailto:sales@hvinc.com)

© **COPYRIGHT 2021 - HIGH VOLTAGE, INC.** – Manufacturers of high voltage test equipment. Products include portable VLF AC .1Hz to .01Hz. Very Low Frequency, sinewave output hipots up to 200 kV; Tan delta and PD diagnostic measurement bridges for cable diagnostics, portable switchgear and bottle testers up to 100 kV AC ; Portable DC Hipots/Megohmmeters to 300 kV DC ; Oil Test sets at 60 kV or 100 kV; Aerial lift and bucket truck testers to 300 kV AC; High Power AC Dielectric test sets up to 300 kV AC @ 40 KVA; OHM Check concentric neutral tester; Controlled energy cable fault locators, Radar and Tracing devices; 150 kV and 300 kV HV voltage dividers.